



Series
TAC3

Pocket Tachometer

Multi-Function, NIST Certified



TEST EQUIPMENT

Tachometers

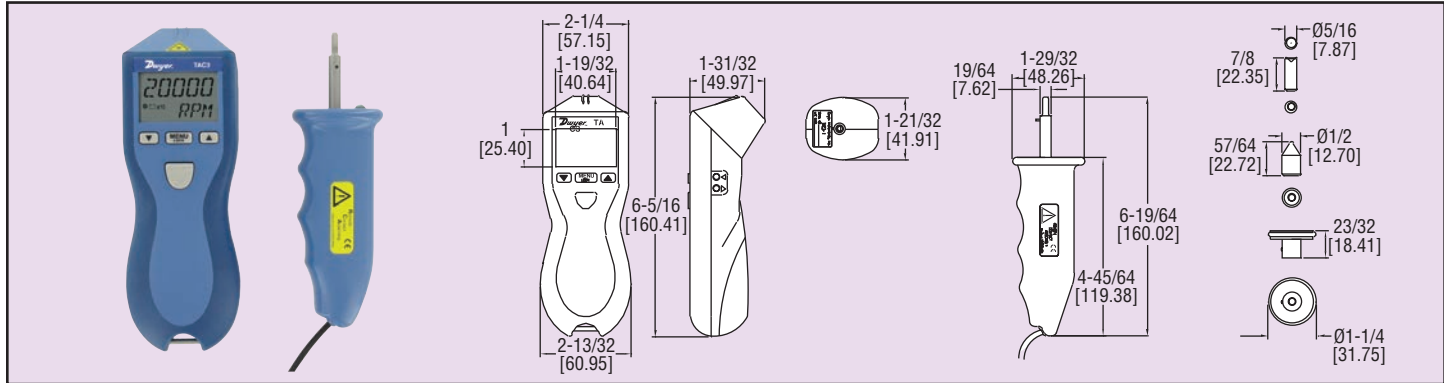

The Series TAC3 Pocket Tachometer measures and displays rotational speed of saw blades, grinders, engines, motors, and conveyor belts. The unique ergonomic design provides direct line-of-sight viewing of display and target. Easy-to-read 5-digit alphanumeric dual LCD also displays on-target, continuous measurement, laser and low battery indication. Measurements of up to 999,999 can be viewed with the on-screen multiplier.

The Model TAC3 is a 32 function tachometer/ratemeter, totalizer/counter, and timer. It is programmable to read in English or Metric units. An input socket accepts remote sensing devices and an output socket allows for pulse output to external indicating devices. The Model TAC3 can be tripod mounted and "Locked-On" for accurate and continuous operation. This tachometer also stores min, max, and last measurement in memory.

Model TAC3-K Kit comes with tachometer, plastic case, remote contact assembly, concave and convex contact tips, 3.9" (10 cm) circumference contact wheel, N.I.S.T. certification, and 5' (1.5 m) of reflective tape. Optional TAC3-91 Remote Optical Sensor allows this unit to measure rps, rpm, or rph in hard to reach locations.

Model TAC3, Pocket tachometer includes 12' of reflective tape and N.I.S.T. certification

Model TAC3-K, Pocket tachometer plus kit

ACCESSORIES

TAC2K-91, Remote optical sensor includes mounting bracket and 8' (2.5 m) cable (optional 100')

TAC-5, Reflective tape, 5' (1.5 m) roll, 1/2" (13 mm) wide

TAC3-1, Remote contact assembly for TAC3 includes 6' (1.8 m) cable, convex and concave tips and 10 cm contact wheel

SPECIFICATIONS

Accuracy: Non-contact: $\pm 0.01\%$ of reading; Contact: $\pm 0.05\%$ of reading; Timer: ± 0.2 s.

Display: Dual LCD display (5 digit upper display / scrolling 5 digit alphanumeric lower display).

Resolution: User-selectable from 0.001 to 1 (10 above 99,999); Timer: 0.1 sec.

Max. Measuring Distance: 25' and up to 70' along perpendicular.

Ambient Operating Temperature: 40 to 105°F (5 to 40°C).

Power Requirements: (2) 1.5 V alkaline batteries, included, user replaceable.

Weight: 7 oz (210 g).

Agency Approvals: CE.

Measurement Ranges

Speed Ranges	Model TAC3	Model TAC3K
Optical*	5 - 200,000 rpm	5 - 200,000 rpm
Contact Tips*	N/A	0.5 - 20,000 rpm
10 cm/12" Wheel*	N/A	0.5 - 12,000 rpm
Linear Menu	Linear Menu	10 cm
Inches/Min*	N/A	1.969 - 78,740
Feet/Min*	N/A	0.164 - 6,561.7
Yards/Min*	N/A	0.055 - 2,187.2
Miles/Hour	N/A	0.002 - 74.564
Centimeters/Min*	N/A	5.000 - 200,000
Meters/Min*	N/A	0.050 - 2,000.0
Totalizer/Counter	0 - 999,999 counts	0 - 999,999 revolutions**
Timer (Stopwatch)	99 min, 59 sec, 0.9 sec	99 min, 59 sec, 0.9 sec

*Also reads units per second and per hour.

**Also totalizes inches, feet, yards, centimeters, and meters.