

MAGNEHELIC® DIFFERENTIAL PRESSURE GAGES

Indicate Positive, Negative or Differential, Accurate within 1%



Standard Magnehelic® Gage



High Accuracy Magnehelic® Gage
Note: Shown with optional -SS bezel

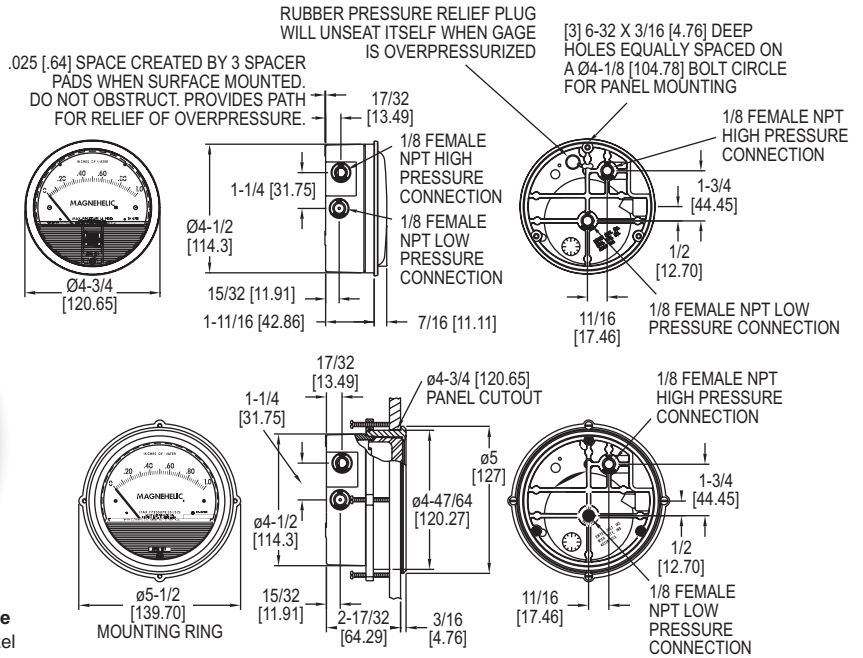

Select the **Series 2000 Magnehelic® Differential Pressure Gages** for a versatile low differential pressure gage with a wide choice of 81 models and 27 options to choose from. Using Dwyer's simple, frictionless Magnehelic® gage movement, it quickly indicates air or non-corrosive gas pressures—either positive, negative (vacuum) or differential. The design resists shock, vibration, over-pressures and is weatherproof to IP67.

Select the -HA High Accuracy Magnehelic® gage option for an accuracy within 1% of full scale. Also included with the -HA option at no extra cost are a mirrored scale overlay and a 6 point calibration certificate.

FEATURES/BENEFITS

- Easy to read gage through undistorted plastic face permits viewing from far away
- Patented design provides quick response to pressure changes means no delay in assessing critical situations
- Durable and rugged housing and high-quality components combine to provide long-service life and minimized down-time
- High accuracy option is twice as accurate as the standard Magnehelic® gage

APPLICATIONS

- Filter monitoring
- Air velocity with Dwyer pitot tube
- Blower vacuum monitoring
- Fan pressure indication
- Duct, room or building pressures
- Clean room positive pressure indication

ACCESSORIES

Model	Description
A-432	Portable kit; combine carrying case with any Magnehelic® gage of standard range, except high pressure connection. Includes 9 ft (2.7 m) of 3/16" ID rubber tubing, standhang bracket and terminal tube with holder
A-605	Air filter gage accessory kit; adapts any standard Magnehelic® gage for use as an air filter gage. Includes aluminum surface mounting bracket with screws, two 5 ft (1.5 m) lengths of 1/4" aluminum tubing, two static pressure tips and two molded plastic vent valves, integral compression fittings on both tips and valves
A-605B	Air filter gage accessory kit; air filter kit with two plastic open/close valves, two 4" steel static tips, plastic tubing and mounting flange
A-605C	Air filter gage accessory kit; air filter kit with two plastic open/close valves, two plastic static tips, plastic tubing and mounting flange

SPECIFICATIONS

Service: Air and non-combustible, compatible gases (natural gas option available). **Note:** May be used with hydrogen. Order a Buna-N diaphragm. Pressures must be less than 35 psi.

Wetted Materials: Consult factory.

Housing: Die cast aluminum case and bezel, with acrylic cover. Exterior finish is coated gray to withstand 168 hour salt spray corrosion test.

Accuracy: ±2% (-HA model ±1) of FS (±3% (-HA ±1.5%) on -0, -100PA, -125PA, -10MM and ±4% (-HA ±2%) on -00, -60PA, -6MM ranges), throughout range at 70°F (21.1°C).

Pressure Limits: -20 in Hg to 15 psig (-0.677 to 1.034 bar); MP option: 35 psig (2.41 bar); HP option: 80 psig (5.52 bar).

Enclosure Rating: IP67.

Overpressure: Relief plug opens at approximately 25 psig (1.72 bar), standard gages only. ⚠

Temperature Limits: 20 to 140°F* (-6.67 to 60°C). -20°F (-28°C) with low temperature option.

Size: 4" (101.6 mm) diameter dial face.

Mounting Orientation: Diaphragm in vertical position. Consult factory for other position orientations.

Process Connections: 1/8" female NPT duplicate high and low pressure taps - one pair side and one pair back.

Weight: 1 lb 2 oz (510 g), MP & HP 2 lb 2 oz (963 g).

Standard Accessories: Two 1/8" NPT plugs for duplicate pressure taps, two 1/8" pipe thread to rubber tubing adapter, and three flush mounting adapters with screws. (Mounting and snap ring retainer substituted for three adapters in MP & HP gage accessories.)

Agency Approvals: Meets the technical requirements of EU Directive 2011/65/EU (RoHS II). **Note:** -SP models not RoHS approved.

Note: For applications with high cycle rate within gage total pressure rating, next higher rating is recommended. See Medium and High pressure options.

*Low temperature models available as special options.



A-432



A-605

MAGNEHELIC® DIFFERENTIAL PRESSURE GAGES

Indicate Positive, Negative or Differential, Accurate within 1%

Bezel provides flange for flush mounting in panel.

Clear plastic face is highly resistant to breakage. Provides undistorted viewing of pointer and scale.

Precision litho-printed scale is accurate and easy to read.

Calibrated range spring is fat spring steel. Small amplitude of motion assures consistency and long life. It reacts to pressure on diaphragm. Live length adjustable for calibration.

Red tipped pointer of heat treated aluminum tubing is easy to see. It is rigidly mounted on the helix shaft.

Pointer stops of molded rubber prevent pointer over-travel without damage.

"Wishbone" assembly provides mounting for helix, helix bearings and pointer shaft.

Jeweled bearings are shock-resistant mounted; provide virtually friction-free motion for helix. Motion damped with high viscosity silicone fluid.

Helix is precision made from an alloy of high magnetic permeability. Mounted in jeweled bearings, it turns freely, following the magnetic field to move the pointer across the scale.

Zero adjustment screw is conveniently located in the plastic cover, and is accessible without removing cover. O-ring seal provides pressure tightness.

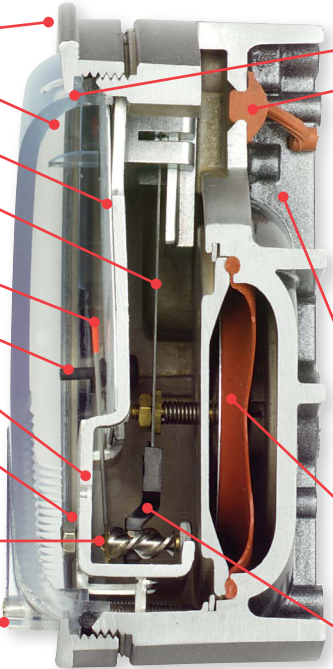

O-ring seal for cover assures pressure integrity of case.

OVERPRESSURE PROTECTION

Blowout plug is comprised of a rubber plug on the rear which functions as a relief valve by unseating and venting the gage interior when over pressure reaches approximately 25 psig (1.7 bar). To provide a free path for pressure relief, there are four spacer pads which maintain 0.023" clearance when gage is surface mounted. Do not obstruct the gap created by these pads.

The blowout plug is not used on models above 180" of water pressure, medium or high pressure models, or on gages which require an elastomer other than silicone for the diaphragm.

The blowout plug should not be used as a system overpressure control. High supply pressures may still cause the gage to fail due to over pressurization, resulting in property damage or serious injury. Good engineering practices should be utilized to prevent your system from exceeding the ratings of any component.

Die cast aluminum case is precision made and iridite-dipped to withstand 168 hour salt spray corrosion test. Exterior finished in baked dark gray hammerloid. One case size is used for all standard pressure options, and for both surface and flush mounting.

Silicone rubber diaphragm with integrally molded O-ring is supported by front and rear plates. It is locked and sealed in position with a sealing plate and retaining ring. Diaphragm motion is restricted to prevent damage due to overpressures.

Samarium Cobalt magnet mounted at one end of range spring rotates helix without mechanical linkages.

MODEL CHART

Model	Range, Inches of Water	Model	Range, PSI	Model	Range, MM of Water	Model	Range, kPa	Dual Scale Air Velocity Units For use with pitot tube	
2000-00N†**	0.05-0.2	2201	0-1	2000-6MM†**	0-6	2000-0.5KPA	0-0.5	Model	Range, in w.c./ Velocity F.P.M.
2000-00†**	0-25	2202	0-2	2000-10MM†*	0-10	2000-1KPA	0-1		
2000-0†*	0-50	2203	0-3	2000-15MM	0-15	2000-1.5KPA	0-1.5	2000-00AV†**	0-.25/ 300-2000
2001	0-1.0	2204	0-4	2000-25MM	0-25	2000-2KPA	0-2	2000-0AV†*	0-.50/ 500-2800
2002	0-2.0	2205	0-5	2000-30MM	0-30	2000-2.5KPA	0-2.5	2001AV	0-1.0/ 500-4000
2003	0-3.0	2210*	0-10	2000-50MM	0-50	2000-3KPA	0-3	2002AV	0-2.0/ 1000-5600
2004	0-4.0	2215*	0-15	2000-80MM	0-80	2000-4KPA	0-4	2005AV	0-5.0/ 2000-8800
2005	0-5.0	2220*	0-20	2000-100MM	0-100	2000-5KPA	0-5	2010AV	0-10/ 2000-12500
2006	0-6.0	2230**	0-30	2000-125MM	0-125	2000-8KPA	0-8		
2008	0-8.0			2000-150MM	0-150	2000-10KPA	0-10		
2010	0-10			2000-200MM	0-200	2000-15KPA	0-15		
2012	0-12			2000-250MM	0-250	2000-20KPA	0-20		
2015	0-15			2000-300MM	0-300	2000-25KPA	0-25		
2020	0-20	2000-15CM	0-15	Zero Center Ranges		2000-30KPA	0-30		
2025	0-25	2000-20CM	0-20	2300-6MM†**	3-0-3	Zero Center Ranges			
2030	0-30	2000-25CM	0-25	2300-10MM†*	5-0-5	2300-1KPA	.5-0-.5		
2040	0-40	2000-50CM	0-50	2300-20MM†*	10-0-10	2300-2KPA	1-0-1		
2050	0-50	2000-80CM	0-80	Model	Range, Pa	2300-2.5KPA	1.25-0-1.25		
2060	0-60	2000-100CM	0-100	2000-60NPA†**	10-0-50	2300-3KPA	1.5-0-1.5		
2080	0-80	2000-150CM	0-150	2000-60PA†**	0-60	Dual Scale English/Metric Models			
2100	0-100	2000-200CM	0-200	2000-100PA†*	0-100	Model	Range, in w.c.	Range, Pa or kPa	
2120	0-120	2000-250CM	0-250	2000-125PA†*	0-125	2000-00D†**	0-.25	0-62 Pa	
2150	0-150	2000-300CM	0-300	2000-250PA	0-250	2000-0D†*	0-0.5	0-125 Pa	
2160	0-160	Zero Center Ranges		2000-300PA	0-300	2001D	0-1.0	0-250 Pa	
2180*	0-180	2300-4CM	2-0-2	2000-500PA	0-500	2002D	0-2.0	0-500 Pa	
2250*	0-250	2300-10CM	5-0-5	2000-750PA	0-750	2003D	0-3.0	0-750 Pa	
		2300-30CM	15-0-15	2000-1000PA	0-1000	2004D	0-4.0	0-1.0 kPa	
Zero Center Ranges				Zero Center Ranges		2005D	0-5.0	0-1.25 kPa	
2300-00†**	0.125-0-0.125			Model	Range, Pa	2006D	0-6.0	0-1.5 kPa	
2300-0†*	.25-0-.25			2300-60PA†**	30-0-30	2008D	0-8.0	0-2.0 kPa	
2301	.5-0-.5			2300-100PA†*	50-0-50	2010D	0-10	0-2.5 kPa	
2302	1-0-1			2300-120PA	60-0-60	2015D	0-15	0-3.7 kPa	
2304	2-0-2			2300-200PA	100-0-100	2020D	0-20	0-5 kPa	
2310	5-0-5			2300-250PA	125-0-125	2025D	0-25	0-6.2 kPa	
2320	10-0-10			2300-300PA	150-0-150	2050D	0-50	0-12.4 kPa	
2330	15-0-15			2300-500PA	250-0-250	2060D	0-60	0-15 kPa	
				2300-1000PA	500-0-500				

†These ranges calibrated for vertical scale position • Accuracy ±3% ** Accuracy ±4% *MP option standard **HP option standard

VELOCITY AND VOLUMETRIC FLOW UNITS

Scales are available on the Magnehelic® gage that read in velocity units (FPM, m/s) or volumetric flow units (SCFM, m³/s, m³/h). Stocked velocity units with dual range scales in inches w.c. and feet per minute are shown above. For other ranges contact the factory. When ordering volumetric flow scales please specify the maximum flow rate and its corresponding pressure. Example: 0.5 in w.c. = 16,000 CFM.

ACCESSORIES

Model	Description
A-321	Safety relief valve
A-448	3-piece magnet kit for mounting Magnehelic® gage directly to magnetic surface
A-135	Rubber gasket for panel mounting
A-401	Plastic carry case
A-310A	3-way vent valves. In applications where pressure is continuous and the Magnehelic® gage is connected by metal or plastic tubing which cannot be easily removed, we suggest using Dwyer A-310A vent valves to connect gage. Pressure can then be removed to check or re-zero the gage.



A-310A

