

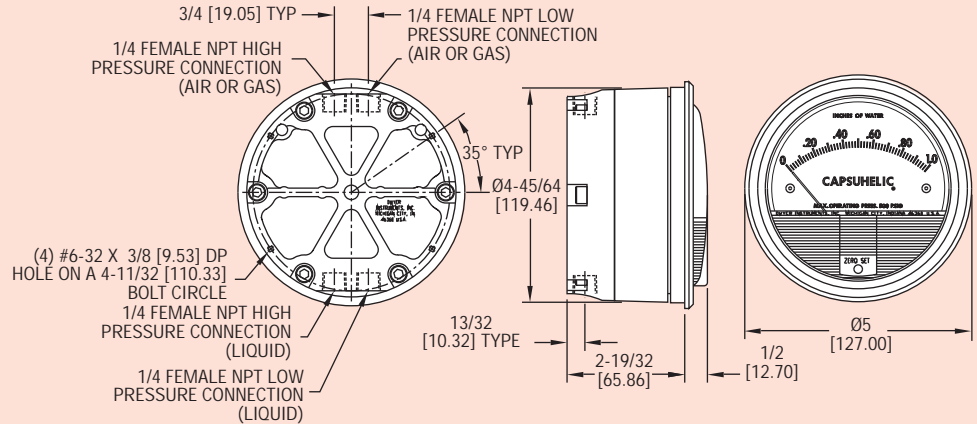

Series  
4000

# Capsuhelic® Differential Pressure Gages

Measures Pressure, Vacuum or Differential, Suitable for Internal Pressures to 500 psig



Capsuhelic® Pressure Gage has a large, easy-to-read 4" (102 mm) dial.

Dimensions, Series 4000 Capsuhelic® Pressure Gages.

The Capsuhelic® gage is designed to give fast, accurate indication of differential pressures. The gage may be used as a readout device when measuring flowing fluids, pressure drop across filters, liquid levels in storage tanks and many other applications involving pressure, vacuum or differential pressure.

Using the basic design of Dwyer's time-proven Magnehelic® gage, the Capsuhelic® gage contains a simple, frictionless movement that permits full scale readings as low as 0.5 inch water column. The pressure being measured is held within a capsule which is an integral part of the gage. This containment of the pressure permits the use of the gage on system pressures of up to 500 psig, even when differentials to be read are less than 0.1 inch w.c. The diaphragm-actuated Capsuhelic® gage requires no filling liquid which might limit its outdoor applications. Zero and range adjustments are made from outside the gage, and there is no need to disassemble the gage in normal service.

**Note:** May be used with hydrogen where pressures are less than 35 psi. Order with a Buna-N diaphragm.

## SPECIFICATIONS

**Service:** Aluminum case: Air and compatible gases and oil based liquids;

Brass case: Air and compatible gases and water based liquids.

**Wetted Materials:** Consult factory.

**Housing:** Die cast aluminum with impregnated hard coating, standard. Optional forged brass housing is required for water or water based fluids. Special material diaphragms available, contact factory.

**Accuracy:** ±3% of full scale at 70°F (21.1°C). (±2% on 4000S models, ±4% on 4200, 4210, 4215, 4220, 4300, 4400, and 4500).

**Pressure Limits:** -20" Hg to 500 psig. (-0.677 bar to 34.4 bar).

**Temperature Limits:** 20 to 200°F (-6.67 to 93.3°C).

**Size:** 4" (101.6 mm) diameter dial face.

**Mounting Orientation:** Diaphragm in vertical position. Consult factory for other position orientations.

**Process Connections:** 1/4" female NPT high and low pressure taps, duplicated - one pair top for air and gas, and one pair bottom for liquids.

**Weight:** 3 lb, 3 oz (1.45 kg) aluminum case; 7 lb, 13 oz (3.54 kg) brass case.

**Standard Accessories:** Two 1/4" NPT plugs for duplicate pressure taps, four flush mounting adapters with screws and four surface mounting screws.

## MOUNTING

Capsuhelic® gages may be flush mounted in a panel or surface mounted. Hardware is included for either. For flush mounting, a 4-13/16" diameter cutout in panel is required. Where high shock or vibration are problems, order optional A-496 Heavy Duty flush mount bracket. Optional A-610 kit provides simple means of attaching gage to 1-1/4"-2" horizontal or vertical pipe. Installation is same as Magnehelic® gage shown on page 4. All standard models are calibrated for vertical mounting. Gages with ranges above 5 in. w.c. can be factory calibrated for horizontal or inclined mounting on special order.



Flush mounted in panel.



Back view shows flush mounting adapters.



Back view for surface mounting.

## OPTIONS & ACCESSORIES

### Adjustable Signal Flag

Integral with plastic gage cover; has external reset screw. May be ordered factory installed on gage or separately for field installation. Specify ASF suffix after model number.

### A-314 Bleed Fitting

For easier, safer purging of trapped air when using gage with liquids. Also useful for draining condensate when installed in lower ports. To open, simply loosen hex nut. Solid brass.

### Forged Brass Case

For applications involving water or water based liquids. To order, add suffix "B" after model number. Example: 4205B.

### Transparent Scale Overlays

Available in bright red, green or yellow to accent critical pressure zones. Specify which color and portion of scale to be covered with each.

### A-471 Portable Kit

Includes plastic case, mounting bracket, A-309 3-way manifold valve, (2) A-230 high pressure hoses and all necessary fittings. Assembly required. Gage not included.

