

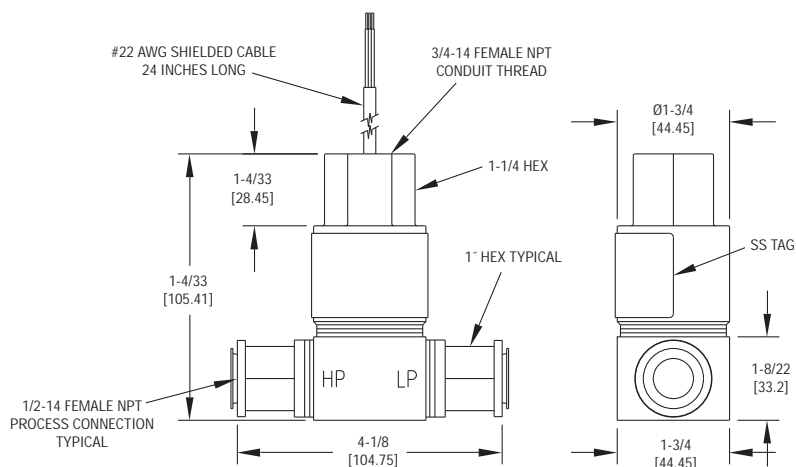

Series 636D Fixed Range Differential Pressure Transmitter

Specifications - Installation and Operating Instructions



The **Series 636D** is an all stainless steel differential pressure transmitter that was designed to endure harsh environmental and media conditions. This transmitter is CSA approved explosion-proof for use in the specified, hazardous locations and also meets NACE standards for offshore applications. The Series 636D is also weatherproof and has a NEMA 4 enclosure rating. With all 316L stainless steel wetted materials this unit is compatible with most media.

The design of the Series 636D transmitter allows for quick and inexpensive installation. Its light weight and slim profile eliminate complicated mounting hardware and allows for installation where space is limited. The piezoresistive sensing element utilizes a Wheatstone bridge to correlate a change in resistance to change in the process pressure. This series is offered with either a 4-20 mA output or a 1-5 VDC output.

SPECIFICATIONS

Service: Compatible gases, liquids, or vapors.

Wetted Materials: Types 316L SS.

Accuracy: BFSL: $\pm 0.5\%$ F.S. (includes linearity, hysteresis, & repeatability).

Stability: $\pm 1.0\%$ F.S./yr.

Pressure Limits: 3 x full scale differential pressure; Burst: 2500 psig.

Temperature Limits:

Ambient Operating: -40 to 140°F (-40 to 60°C).

Process Interface: -40 to 212°F (-40 to 100°C).

Storage: -40 to 212°F (-40 to 100°C).

Compensated Temperature Range: -20 to 160°F (-29 to 71°C).

Thermal Effect: $\pm 2\%$ F.S./ 50°F (reference to 77°F).

Power Requirements: 12-30 VDC for 4-20 mA outputs; 8-14 VDC for 1-5 VDC outputs, both with reverse polarity protection.

Output Signal: 4-20 mA DC or 1-5 VDC.

Zero and Span Adjustment: Fixed.

Response Time: 20 ms.

Loop Resistance: 900 ohms max @ 30 VDC for current outputs. For voltage outputs, minimum lead resistance 50k ohms.

Current Consumption: 4-20 mA for current output models; 3 mA for voltage output models.

Electrical Connections: 2 ft, 22 AWG cable; 3/4" female NPT conduit.

Process Connections: Two 1/2" female NPT.

Enclosure Rating: NEMA 4 (IP65).

Mounting Orientation: ± 0.05 psi/ 90° rotation from horizontal.

Weight: 1.8 lb (0.82 kg).

Agency Approvals: CSA approved explosion-proof for Class I, Division 1, Groups B, C, and D; Class II, Groups E, F, and G; Class III.

INSTALLATION

Care should be taken during installation to prevent condensate accumulation in the conduit compartment or sediment accumulation in the diaphragm chambers. It is good practice to install the transmitter with the conduit connection pointing down or to utilize a conduit drain or drip leg where this is not possible. Calibration of this transmitter is performed with the process connections in the horizontal plane. The specified worst case inaccuracies due to mounting orientation would occur when the process connections are in the vertical plane. A pipe joint compound or pipe thread sealant tape thread should be used to assure a leak-proof process connection.

ELECTRICAL CONNECTIONS

CAUTION: Do not exceed specified supply voltage rating. Permanent damage not covered by warranty will result. This unit is not designed for AC line voltage operation. Power must be off while wiring connections are being made.

An external power supply delivering 12-30 VDC with a minimum current capability of 40 mA DC (per transmitter) or 8-14 VDC when using a 1-5 VDC output model, must be used to power the control loop. See Fig. A.

To comply with good electrical practice, it is recommended that the transmitter be grounded. This can be accomplished through either the green wire or the transmitter case. To avoid a "ground loop" condition, DO NOT use both. The shield/drain wire is not connected to the case. This shield/drain is normally tied to ground at the receiver for optimal noise rejection.

The range of appropriate loop resistance, including the receiver load resistance for the DC power supply being used is limited to that expressed by the graph in Fig. B.

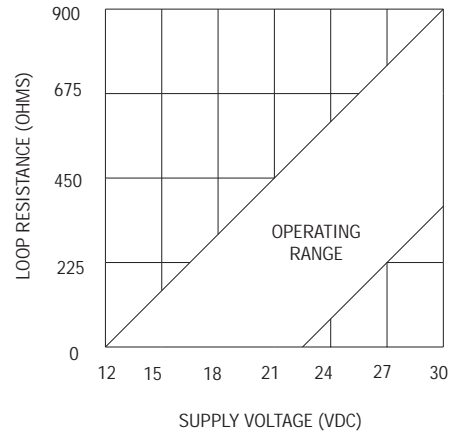

Fig. B

MAINTENANCE

Upon final installation of the Series 636D Fixed Range Differential Pressure Transmitter and the companion receiver, no routine maintenance is required. A periodic check of the system calibration is recommended. The Series 636D Fixed Range Differential Pressure Transmitter is not field serviceable and should be returned if repair is needed (field repair should not be attempted and may void warranty). Be sure to include a brief description of the problem plus any relevant application notes. Contact customer service to receive a return goods authorization number before shipping.

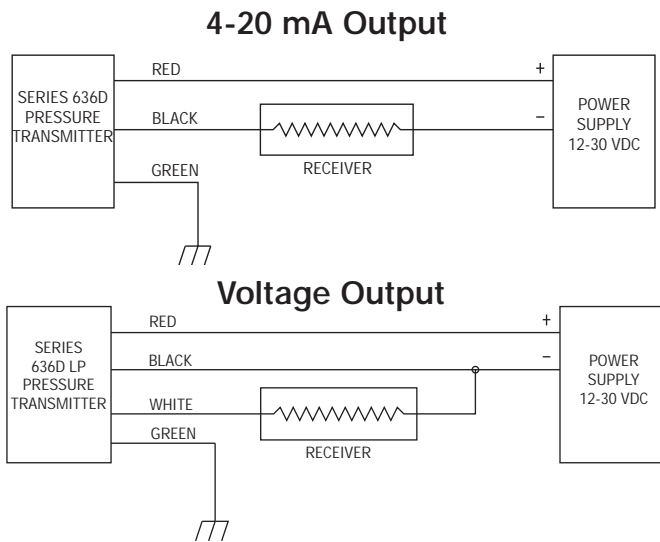

Fig. A