

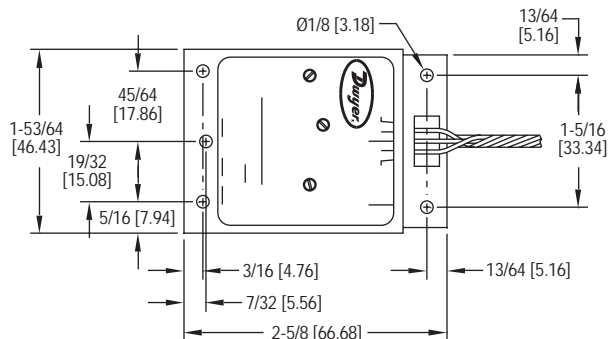

Series 650 Temperature Transmitter

Specifications - Installation and Operating Instructions



The Dwyer Series 650 Temperature Transmitter provides a 4-20 mA control signal output which varies in linear relationship to the temperature of the silicon transducer in the sensing probe. The low cost and small size of the Series 650 Temperature Transmitter make it ideal for a wide variety of multipoint temperature monitoring applications. Non-polarized power connections simplify electrical connection to any power source providing 12-35 volts DC.

Models are stocked in three popular ranges, all with factory calibration within 0.3% and linearity within 0.25% of span. Units can be field calibrated to limits shown in chart at right. See calibration instructions on page 2 for procedure.

INSTALLATION

Location: Select a location where the temperature of the unit will remain between 0° and 70°C. The location must also be within the 7 foot length of the sensing probe cable. The power supply and the receiving control device can be located up to several hundred feet from the transmitter itself.

Position: The Series 650 can be mounted in any position. It is advisable to keep the adjustment screws and connector plug easily accessible for future re-calibration or service.

Mounting: The Series 650 electronics package can be attached to mounting surface by means of the five holes provided. Refer to the dimensional drawing, Figure A for these hole spacings. The small size of the transmitter electronics package allows it to be mounted inside a standard household single gang electrical box, if preferred. When mounting the temperature sensing probe in a sheet metal duct or on other thin walled enclosures, the use of the Dwyer Model A-325 Duct Mounting Kit is

SPECIFICATIONS

Power Supply: 12-35 volts DC.

Output Signal: 4-20 mA DC.

Voltage Stability: Output error less than 0.01% of span over the specified supply voltage range.

Linearity: Within 0.25% of span.

Initial Calibration: Within 0.3% of span at 20°C/68°F ambient.

Thermal Drift: Less than 0.5% of span over ambient temperature range of 0-50°C, 32-122°F.

Ambient Operating Temperature (Electronics): 0-70°C, 32-158°F.

Maximum Temperature (Probe): 204°C/400°F.

Probe Construction: 6' long, 0.25" O.D., Type 304 Stainless Steel.

Note: Special factory calibrated ranges are available within the limits of - 55°C and + 180°C. Contact factory with specifications for price and availability.

SERIES 650 TRANSMITTER MODELS & RANGES

FACTORY CALIBRATION MODEL NUMBER	RANGE AS STOCKED	FIELD CALIBRATION			
		TOTAL RANGE LIMITS		LOW END LIMITS	
		MIN. SPAN	MAX. SPAN	MIN.	MAX.
650-1	-23° to + 10°C	24°C	48°C	- 32°C	- 14°C
650-2	-7° to + 49°C	37°C	150°C	- 12°C	+ 6°C
650-3	0° to + 100°C	37°C	150°C	- 12°C	+ 6°C

To achieve TOTAL RANGE LIMITS above (with 4-20 mA output), the lowest temperature being sensed (at 4 mA) must be between the minimum and maximum values under LOW END LIMITS.

recommended. Refer to Figure B for details on this arrangement. Other customer designed probe mounting configurations can be used as long as the tip of the sensing probe is in the space where temperature is to be controlled.

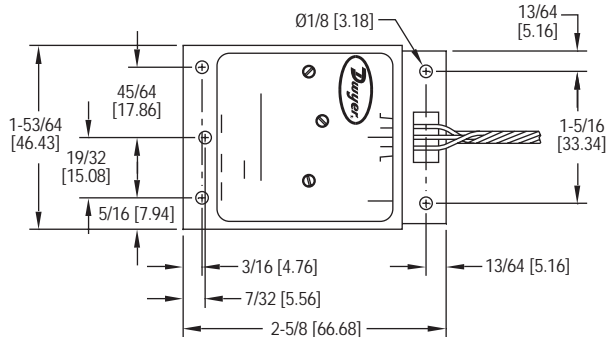

FIGURE A

A-325 DUCT MOUNTING KIT

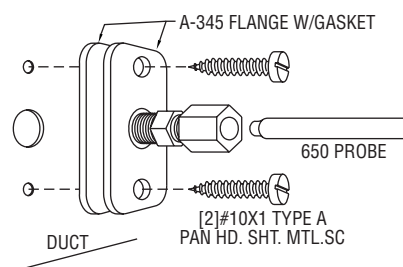

FIGURE B

ELECTRICAL CONNECTIONS

CAUTION: DO NOT EXCEED SPECIFIED SUPPLY VOLTAGE RATINGS. PERMANENT DAMAGE NOT COVERED BY WARRANTY WILL RESULT. THIS UNIT IS NOT DESIGNED FOR AC LINE VOLTAGE OPERATION.

The Series 650 Transmitter is a two wire device and the two brown leads exiting from the transmitter electronics package need only be connected in series with the control loop power supply and the desired receiver. The power supply should be capable of delivering a minimum of 30 milliamps at any voltage between 12 and 35 VDC. Refer to the schematic diagram in Figure C for details on the electrical connections. The transmitter connections are non-polarized so either brown lead can be utilized when making the control loop connections as shown. The insulation has been stripped from the ends of these brown leads to provide easy connection to a terminal block or to allow solder connections to the control loop circuit.

Before energizing the control loop power supply, connect the temperature sensing probe cable to the electronics package by means of the five pin cable plug and the circuit board connector. Be sure the cable plug is properly oriented according to the lead colors as indicated on the transmitter label. When the plug is properly inserted, the three temperature sensor leads will lead away from the electronics package. Do not make any connections to the cable connector pins labeled T1 and T2 as these are used only for recalibration purposes; refer to the next section on Temperature Recalibration.

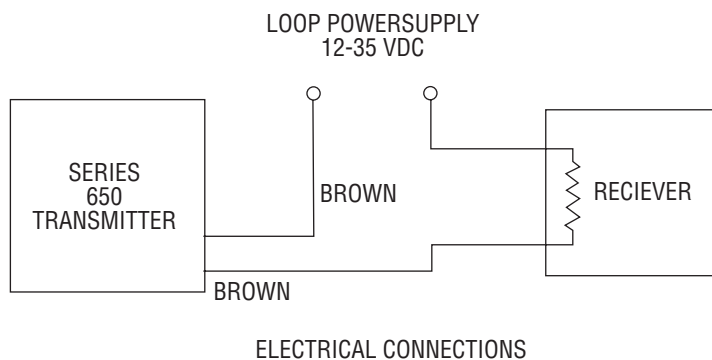

FIGURE C

TEMPERATURE RECALIBRATION

Each Series 650 Transmitter is factory calibrated to the range given in the model number chart and marked on the transmitter label. However, special calibrations can also be achieved by following the procedure below. For purposes of clarification in these instructions, the low end of the range is defined as that temperature which applied to the sensor produces 4 mA of current in the loop. The high end of the range is that temperature which applied to the sensor produces 20 mA of current. The range or span is the difference between low and high end temperatures. See examples at right illustrating use of Model and Range chart on page 1.

To recalibrate, you will require accurately known low and high temperature sources along with a sensitive volt-ohm-milliamp (VOM) meter. One convenient 0°C/32°F temperature source is an ice bath in an insulated bottle.* A laboratory temperature chamber can also be used or, if forced to improvise, a laboratory grade mercury thermometer of the proper range in a thermal mass along with the probe can be used. However, the latter approach is not likely to achieve the specified accuracy of the Series 650 Transmitter.

*Note: The sensing probe tip is hermetically sealed and may be used to monitor water temperature.

To change the temperature range, follow this procedure.

1. With the transmitter connected to a companion receiver and an appropriate power supply, apply power to the system. With the sensor at the required low end of the temperature range, select a low DC voltage range on the VOM and connect the meter across the control loop pins on the connector labeled T1 and T2. If a down scale reading is obtained, reverse the volt meter connections until an up scale reading is obtained. Using a small screwdriver, turn the screw identified on the transmitter label as NULL until the voltage across pins T1 and T2 is zero. Keep switching to a lower voltage range while making this adjustment. Ideally, when the adjustment is completed there will be less than one millivolt difference between pins T1 and T2.
2. Switching to a full scale range of approximately 30 mA on the VOM, insert the meter in series with one of the current loop leads to monitor the current flow in the loop. Again, if a down scale reading is obtained, reverse the leads to the VOM. With the sensing probe stabilized at the low end of the required temperature range, adjust the screw labeled LOW CAL for a reading of exactly 4 mA on the VOM.
3. Increase the temperature of the sensor probe tip to the high end of the range chosen. When the temperature has stabilized at the high end, adjust the screw labeled HIGH CAL for a reading of exactly 20 mA on the VOM.
4. As the above adjustments are independent of one another, no further adjustment is required. Remove the VOM from the current loop and proceed with final installation of the transmitter.

EXAMPLES

A. Can any of the standard models be recalibrated to a temperature range of -16°C to +20°C?

YES. Referring to specifications for Model 650-1, -16°C is within low end limits of -32°C to -14°C and the span of 36°C (-16 to +20) is within the total range limit of 24°C to 48°C.

B. Can any of the standard models be recalibrated to a temperature range of -20°C to +80°C?

NO. Referring to specifications for Model 650-1, -20°C is within low end limits of -32°C to -14°C but the total range of 100°C (-20 to +80) exceeds the limit of 24°C to 48°C. While the range is within limits for Models 650-2 and 650-3, the -20°C minimum temperature is lower than the low end limits of -12°C to +6°C for those two models.

MULTIPLE RECEIVER INSTALLATION

An advantage of the standard 4-20 mA output signal provided by the Series 650 Transmitter is that any number of receivers can be connected in Series in the current loop. Thus, an A-701 Digital Readout Accessory, an analog panel meter, a chart recorder, process controlling equipment, (or any combination of these devices) can be operated simultaneously. It is only necessary that these devices all be equipped with a standard 4-20 mA input and that proper polarity of the input connections be observed when inserting the device in the current loop. If any of the receiving devices displays a negative or downscale reading, this indicates that the signal input leads are reversed.

MAINTENANCE

Upon final installation of the Series 650 Transmitter and the companion receiver, including the A-701 Digital Readout, no routine maintenance is required. A periodic check of system calibration is recommended. The Series 650 Temperature Transmitter is not field serviceable and should be returned to the factory if service is required. The A-701 Digital Readout should be returned to the manufacturer if service is required. Refer to the A-701 instruction sheet.

Note: Interchanging sensing probes requires recalibration to maintain published accuracies.