

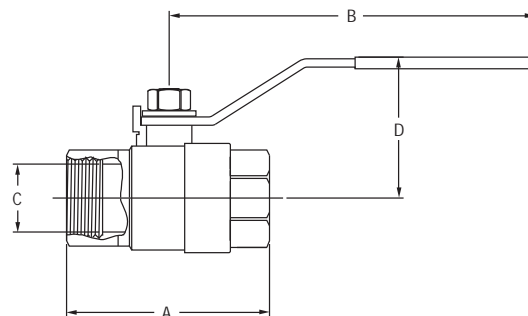

Series BV2MB Two-Piece Hand Lever Brass Ball Valve

Specifications - Installation and Operating Instructions



DIMENSIONS

Size	A (Ref)	B (Ref)	C (Ref)	D (Ref)
1/4"	1.800	3.800	.393	1.250
3/8"	2.000	3.800	.393	1.250
1/2"	2.070	3.800	.551	1.830
3/4"	2.360	3.800	.748	1.950
1"	2.950	4.350	.944	2.170
1-1/4"	3.370	5.470	1.181	2.800
1-1/2"	3.740	5.470	1.496	3.030
2"	4.290	6.380	1.850	3.330
2-1/2"	5.650	8.720	2.440	4.000
3"	6.180	8.720	2.990	4.310

The Series BV2MB is an economical hand lever ball valve for commercial and general industrial use. The Series BV2MB is perfect for water shutoff applications. Valve body, body cap, and ball are made of quality brass. Seats and stem packing are constructed of TFE for long lasting service. Blowout-proof stem provides safety in the event of overpressure. Full port design allows for maximum Cv and minimal pressure drop.

INSTALLATION

Prior to installation, inspect valve and pipe ends to make sure they are free from debris. Material trapped inside the valve can cause damage to the seats and result in leakage. Clean pipe ends and check for proper threading to prevent damage to valve internals.

Use a PTFE based thread sealant applied to the pipe threads. With valve in the OPEN position, install pipe. Use a smooth wrench on the hex portion of the valve, not the valve body, to tighten. Use pipe wrenches on pipe and pipe fittings only.

OPERATION

These valves are bi-directional and can be installed with flow in either direction. Rotate the handle 90 degrees counterclockwise to open and 90 degrees clockwise to close. Check to make sure the process media is compatible with the valve materials. See "Specifications". Do not exceed pressure or temperature maximum ratings.

SPECIFICATIONS

Body: Two-Piece.

End Connections: 1/4" to 3" female NPT.

Pressure Limit: 1/4" to 1": 600 psi (41.4 bar), 1-1/4" to 2": 400 psi (27.6 bar), 2-1/2" to 3": 200 psi (13.8 bar) WOG.

Wetted Materials: Body and body cap: forged brass (ASTM B283-C37700); ball and stem: brass; seat and packing: TFE.

Temperature Limit: 10 to 200°F (-12 to 93°C).

Other Materials: Body seal: rubber; handle: plated steel; nut and gasket: brass.

MAINTENANCE

The Series BV2MB is a non-repairable valve. The only maintenance required is the occasional tightening of the packing gland nut.