



Series  
CFS

# Cable Float Switch

No Hazardous Mercury, Adjustable Counterweight

CE

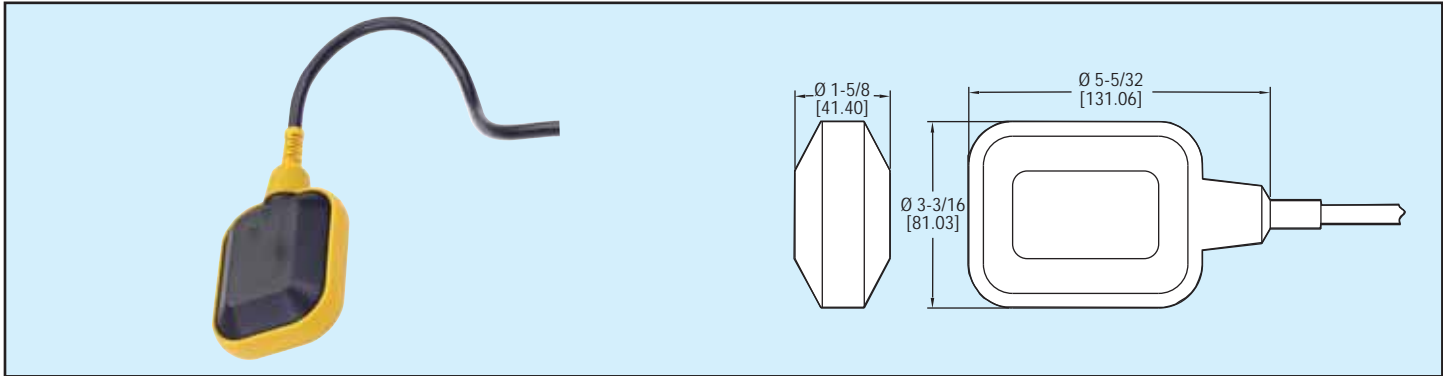

**Control the level** of liquids in filling or draining reservoirs and tanks with the Series CFS. The mercury-free switch is designed with an inverter microswitch housed in a polypropylene cover. The unit includes a counterweight to adjust the stop and start levels of pump up/pump down application.

Model	Cable Length
CFS-2	6.5 ft (2 m)
CFS-10	32.8 ft (10 m)

## SPECIFICATIONS

**Service:** Compatible liquids.

**Wetted Materials:** Polypropylene housing, PVC cable.

**Temperature Limits:** 140°F (60°C).

**Pressure Limits:** 60 psi (4 bar).

**Enclosure Rating:** NEMA 6 (IP68).

**Switch Type:** SPDT.

**Electrical Rating:** 10 A @ 250 VAC, resistive.

**Mounting Orientation:** Vertical.

**Weight:** CFS-2: 1.416 lb (.62 kg); CFS-10: 3.316 lb (1.48 kg).

**Agency Approvals:** CE.