

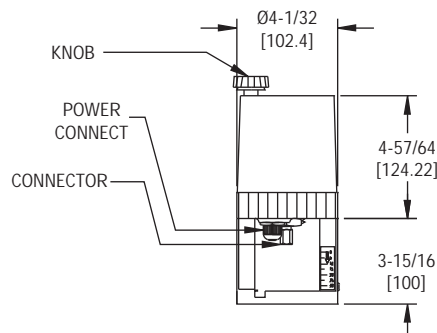

Series EVA2 and EVA3 Electric Actuators

Specifications - Installation and Operating Instructions



The Series EVA2 and EVA3 Electric Actuators are designed to mount directly onto the Series GV globe valves, creating a complete, low cost, and compact control valve package. Floating or modulating control inputs are available, and the 24 VAC synchronic motor includes a magnetic clutch to protect the motor in stall conditions. Actuators are ruggedly constructed with a fire-proof ABS housing and robust aluminum bracket. Features include a visual position indicator and manual override to make this actuator an excellent choice for any size area, large or small.

FEATURES

- Manual override
- Compact size
- Floating control or selectable 0-10 VDC or 4-20 mA proportional control
- Reversible direction on proportional models
- Magnetic clutch protects motor in stall conditions

Model	Actuator Action	Output Force	Valve Size	Compatible Valve Models
EVA2F	Floating	225 lb (1000 N)	1" to 2-1/2"	GV2__, GV3__
EVA2M	Modulating	225 lb (1000 N)	1" to 2-1/2"	GV2__, GV3__
EVA3F	Floating	337 lb (1500 N)	1" to 2-1/2"	GV2__, GV3__
EVA3M	Modulating	337 lb (1500 N)	1" to 2-1/2"	GV2__, GV3__

SPECIFICATIONS

SERIES EVA2, EVA3

Output Force: EVA2: 225 lb (1000 N); EVA3: 337 lb (1500 N).

Power Requirements: 24 VAC.

Power Consumption: EVA2F (EVA3F): 5.5 VA; EVA2M (EVA3M): 7.5 VA.

Cycle Time: EVA2F (EVA2M): 97 sec/in. (3.8 sec/mm); EVA3F (EVA3M): 164 sec/in. (6.45 sec/mm).

Enclosure Rating: IP40.

Housing Material: Fire-proof ABS plastic (UL94V-0).

Bracket Material: Aluminum.

Operating Temperature: 36 to 131°F (2 to 55°C).

Storage Temperature: -4 to 149°F (-20 to 65°C).

Humidity Limit: <90%, non-condensing.

Electrical Connection: Screw terminal.

Modulating Input: 0 to 10 VDC or 4 to 20 mA.

Weight: EVA2F (EVA3F): 2.43 lb (1.1 kg); EVA2M (EVA3M): 3.31 lb (1.15 kg).

INSTALLATION

1. Tightly screw the valve connector on the valve body. Please pay attention to the direction of the connector.
2. Install the actuator bracket on the valve connector.
3. Insert the U-type connector into the bracket, and lock the connector nut.
4. Lift up the valve stem and put the lock nut and indicator guide onto it, then rotate the connecting rod of the actuator and let it rotate onto the valve stem. Use spanner to lock the locknut after adjusted into position.
5. In vertical installations, leave enough head room to unscrew the actuator prior to servicing the valve body.
6. Wire the unit according to the appropriate Wiring Diagram.

EVA2F (EVA3F) WIRING DIAGRAM

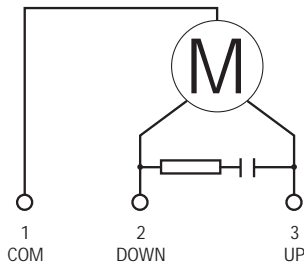

Terminals	Actuator Rod
1-2	Down Extend
1-3	Up Contract

EVA2M (EVA3M) WIRING DIAGRAM

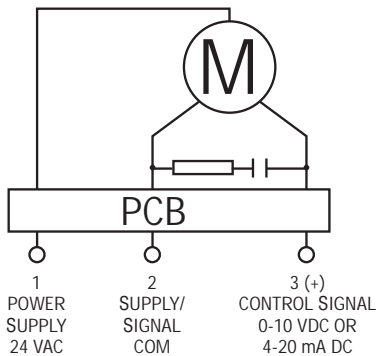

Input Control Signal		Actuator Rod
DA	RA	
Increase	Decrease	Down
Decrease	Increase	Up

Note: Actuator must be protected from dripping water. Damage to internal elements and motor may occur. Do not cover actuator with material that does not permit heat exchange.

OPERATION

1. The actuator is driven by a reversible synchronous motor with a magnetic clutch. The motor can provide stable torsion at stopping conditions due to the magnetic force created by the motor rotor and the magnetic clutch. When power is taken away, the motor will stop at its current position.
2. The signal of the proportional type actuator controls the clockwise or counter-clockwise rotation of the motor.
3. EVA2M (EVA3M) actuators can be jumper selected for 0.51, 0.59, 0.67 or 0.75 inch valve strokes. Factory stroke setting is 0.75".
4. The input control signal is jumper selectable between 0-10V or 4-20 mA DC. Factory setting is 0-10V DC input mode.
5. Direct (DA) or Reverse (RA) direction operation is also jumper selectable. The two states are opposite of each other.

EVA2M (EVA3M) PCB SETTING DIAGRAM

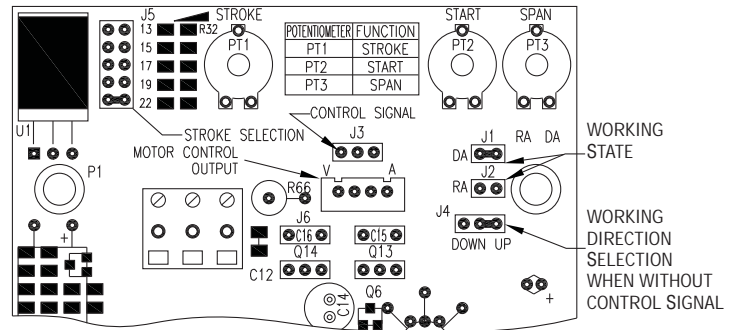

MAINTENANCE

The Series EVA2 and EVA3 Electric Actuators are not field serviceable and should be returned if repair is needed (field repair should not be attempted and may void warranty). Make sure to cut off power supply when disconnecting the actuator from the valve. Contact customer service to receive a return goods authorization number before shipping. Be sure to include a brief description of the problem plus any relevant application notes.