

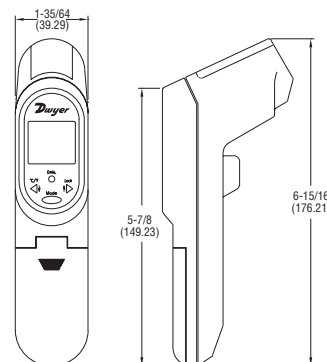

Series IR4 Infrared Non-Contact Thermometer

20:1 Distance-to-Target Ratio, Thermocouple Input, Laser Sighting



For those long range applications, the IR4 Non Contact Infrared Thermometer is the perfect instrument. It has a distance to spot ratio of 20:1 and laser sighting to accurately measure within 1% of reading. The adjustable emissivity allows this thermometer to measure the temperature of virtually any surface. There is no guessing when the battery is low as the IR4 has a battery indicator on its back lit display. This useful hand held has programmable low and high audible alarms built in. The IR4 accepts any K-type thermocouple to display both a IR and a contact reading simultaneously. MAX, MIN, DIF, and AVG can be displayed with a push of a button

SPECIFICATIONS

Measurement Range: -76 to 1400°F (-70 to 760°C).

Accuracy: 1% of reading or 1.8°F (1°C) whichever is greater.

Emissivity Range: 0.95 default - adjustable 0.05 to 1.00 Emissivity.

Distance Spot: 20:1 Optics Ratio.

Resolution: 0.1°F/0.1°C.

Response Time: 1 Second.

Operating Range: 32 to 122°F (0 to 50°C).

Battery Life: Typical 180 hours continuous use (auto power off after 15 sec.). (2) AAA batteries included.

Weight: 3.61 oz (179 g).

Dimensions: 6.9 x 1.54 x 2.83 in (175.2 x 39.0 x 71.9 mm).

Additional Input: K-Type Thermocouple.

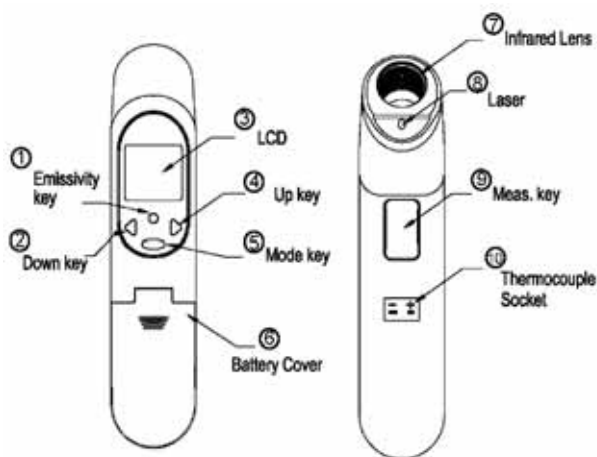

For Continuous Measurement

Press the "UP" key to enter *Lock Mode*. The lock mode is particularly useful for continuous monitoring of temperatures for up to 60 minutes.

EMISSIVITY: Press "Emissivity" key for setting the emissivity, then press "UP" key or "DOWN" key to set the emissivity, then press "MODE" key to confirm it. The emissivity can be changed from 0.10 (10E) to 1 (100E).

OPERATING INSTRUCTIONS

Simply aim the thermometer at the target and press the "MEAS" key to display the surface temperature.

Press "DOWN" key to switch between °F and °C.

Hold down on the "MEAS" key and "DOWN" key for laser.

Function:

Press the "MODE" key for scrolling to display more functions as follows.

E: Will show the emissivity data.

MAX, MIN DIF, AVG: Press "MODE" key for the Maximum (MAX), Difference between MAX and MIN (DIF) and Average (AVG) modes. During the measurement, the special modes reading will be displayed beside the mode icon.

HAL, LAL: Press "UP" key or "DOWN" key to change the High Alarm (HAL) or Lo Alarm (LAL) then press "MEAS" key to confirm it.

PRB: Connect the thermocouple to the thermocouple socket and put the probe in/on the target to be measured, the thermometer will display the temperature automatically without pressing any button. To see the minimum or maximum data during the probe measurement, please hold down the "UP" key or "DOWN" key.

After measuring high temperatures the probe may remain HOT for a while.

LED Error Messages

The thermometer incorporates visual diagnostic messages as follows.

"HI/LOW": "Hi" or "Lo" is displayed when the temperature being measured is outside of the settings of HAL and LAL.

"Er2": Displays when the thermometer is exposed to rapid changes in the ambient temperature.

"Er3": Displays when the ambient temperature exceeds 32°F (0°C) or 122°F (50°C). The thermometer should be allowed plenty of time (minimum 30 minutes) to stabilize to the working/room temperature.

For all other error messages it is necessary to reset the thermometer. To reset it, turn the instrument off, remove the battery and wait for a minimum of one minute, reinsert the battery and turn it on. If the error message remains please contact the Dwyer Customer Service department for further assistance.

Batteries:

The thermometer incorporates visual low battery indication as follows.

Battery OK: Measurements are possible.



Battery Low: Battery needs to be replaced, measurements are still possible.



Battery Exhausted: measurements are not possible. When the low battery icon indicates the battery is low, the batteries should be replaced immediately with AAA, 1.5V batteries.

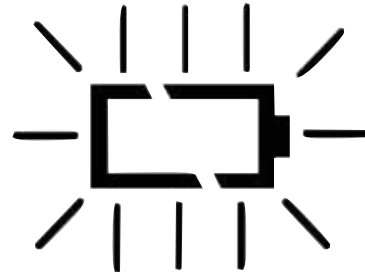

Please Note: It is important to turn the thermometer off before replacing the battery otherwise the thermometer may malfunction. Dispose of used battery promptly and keep away from children.

CAUTION

1. When device is in use, do not look directly into the laser beam - Permanent eye damage may result.
2. Use extreme caution when operating the laser.
3. Never point the device towards anyone's eyes.
4. Keep out of reach of all children.

EMC/RFI

Readings may be affected if the unit is operated within radio frequency electromagnetic field strength of approximately 3 volts per meter, but the performance of the instrument will not be permanently affected. **Note: under the electromagnetic field of 3V/m from 350 to 550 MHz, the maximum error is 14.4°F (8°C).

MAINTENANCE

A periodic check of the system calibration is recommended. The Series IR4 is not field serviceable and should be returned if repair is needed (field repair should not be attempted and may void warranty). Be sure to include a brief description of the problem plus any relevant application notes. Contact customer service to receive a return goods authorization number before shipping.

Storage and Cleaning

The sensor lens is the most delicate part of the thermometer. The lens should be kept clean at all times, care should be taken when cleaning the lens using only a soft cloth or cotton swab with water or medical alcohol. Allowing the lens to fully dry before using the thermometer. Do not submerge any part of the thermometer. The thermometer should be stored at room temperature between -4 and 149°F (-20 to 65°C).