

Model LCT016 Analog Multi Timer

INSTRUCTION MANUAL

LOVE LOVE CONTROLS

a Division of Dwyer Instruments, Incorporated
 PO Box 338 ◯ Michigan City, IN 46361-0338
 (800) 828-4588 ◯ (219) 879-8000
 ◯ FAX (219)872-9057
www.love-controls.com



Version 1.0

This manual primarily describes precautions required in installing and wiring the timer.

Names and functions of respective parts

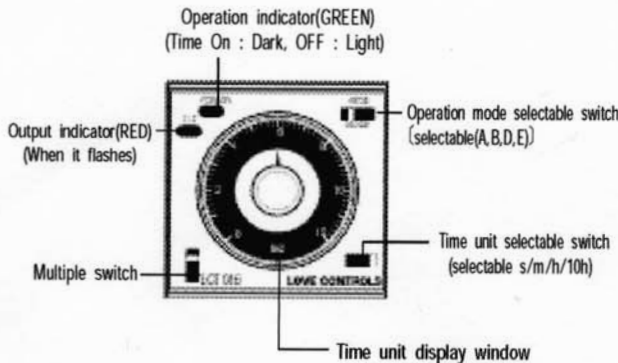

Connections

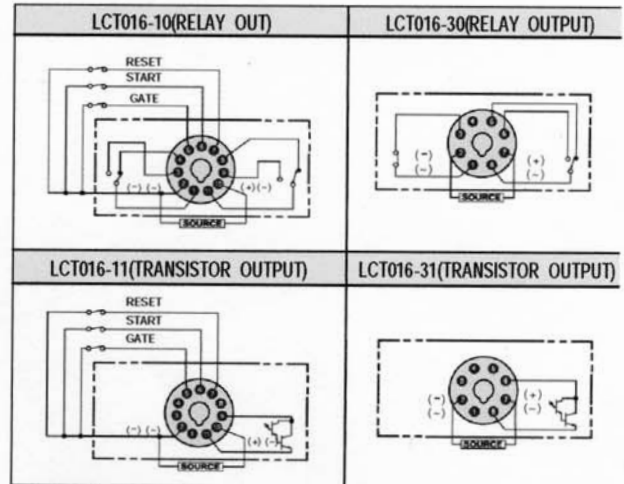

Specifications

Supply voltage	100~240 VAC 50/60 Hz, DC/AC 24 V 50/60 Hz
Operating voltage	85 to 110 % of rated voltage (90~110 % for 12 VDC)
Power consumption	AC : 10 VA, DC : 1 W
Repeat accuracy	±0.3 % max.(as against max. rated time), ±0.3 % ±10 ms max. for 1.2 time setting range
Setting error	±5 % max.(as against max. rated time), ±0.5 % s. max.
Resetting time	0.1 s. max.
Voltage accuracy	±0.5 % max.(as against max. rated time), ±0.5 % ±10 ms max. for 1.2 time setting range
Temperature accuracy	±2 % max.(as against max. rated time), ±2 % ±10 ms max. for 1.2 time setting range
Insulation resistance	100 MΩ min.(at 500 VDC)
Dielectric strength	2 000 VAC for 1 minute
Vibration	Mechanical durability 10~55 Hz double amplitude 0.75 mm
	Malfunction durability 10~55 Hz double amplitude 0.5 mm
Shock	Mechanical durability 300 %
	Malfunction durability 100 %
Life expectancy	Mechanical 10 000 000 operations min.
	Electrical 100 000 operations min. (250 VAC, 5 A load resistance)
Weight	Approx. 90 g

Time range

Max. Rated time	Time unit	s	min	h	×10h
		1, 2	Time setting range	0.12 ~ 1.2	
3	0.3 ~ 3			3 ~ 30	
12	1.2 ~ 12			12 ~ 120	
30	3 ~ 30			30 ~ 300	

Ordering Information

CODE	OUTPUT MODE	PIN	POWER	OUTPUT		
LCT016-10	A:ON-delay	11	100~240 VAC 50/60 Hz 24 VAC · DC 48 VAC · DC	Relay		
LCT016-11	B:Flicker off start D:Signal on/off delay E:Signal off delay			Transistor		
LCT016-30	A:ON-delay			8	110~220 VAC 50/60 Hz 24 VAC · DC	Relay
LCT016-31						Transistor

꺆 Dimensions

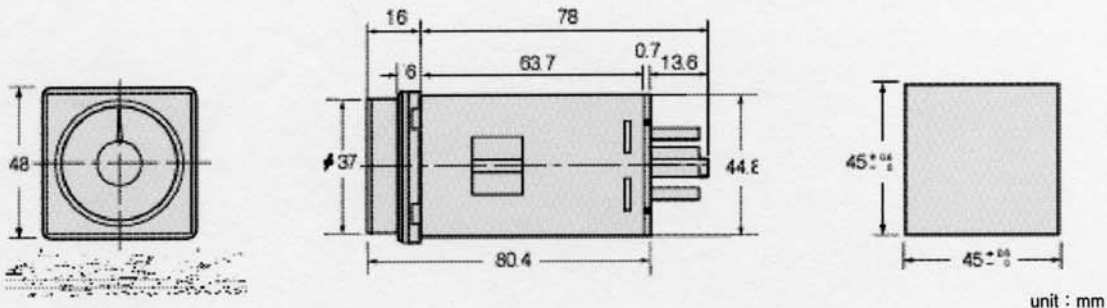

꺆 Timing charts

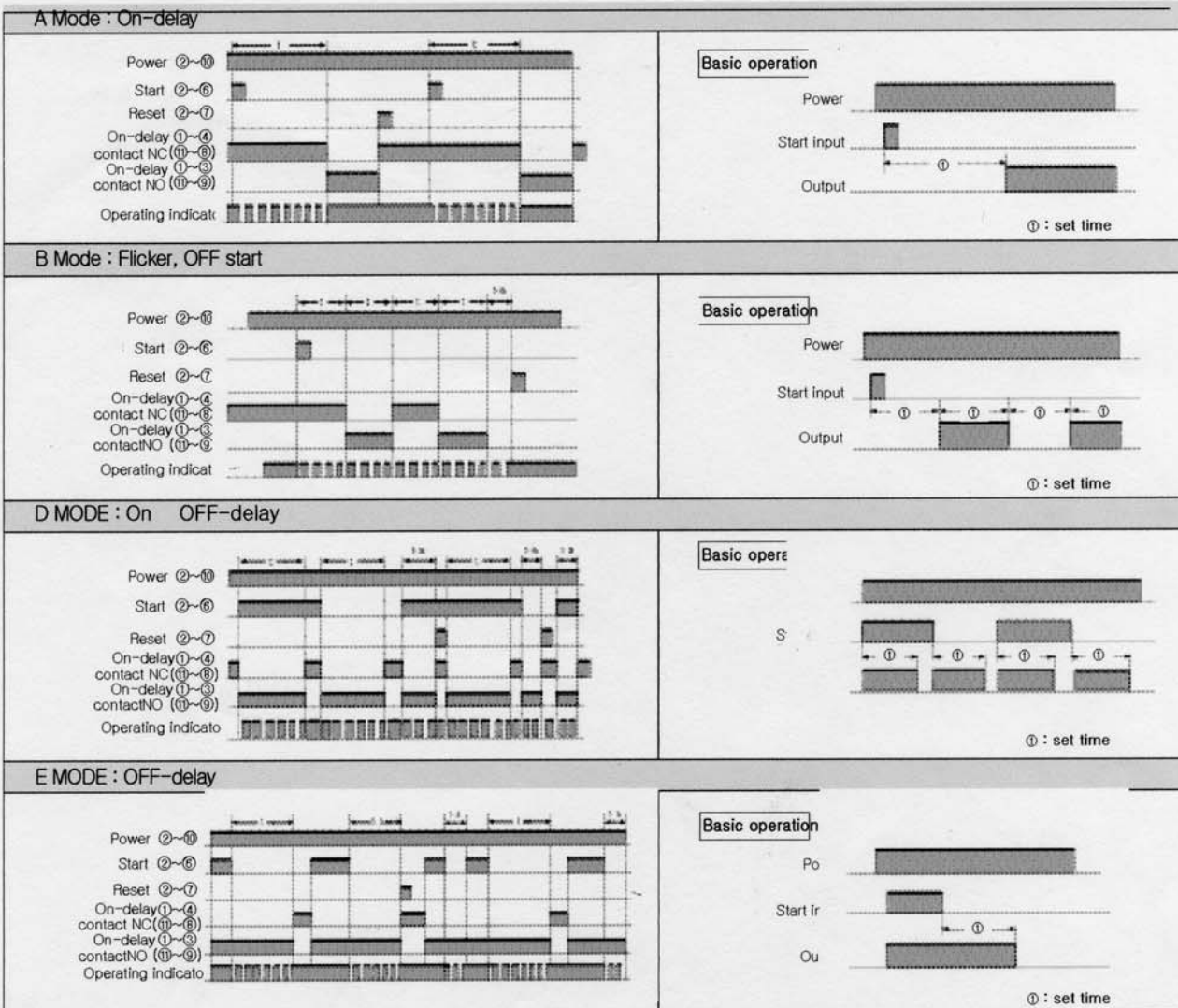

NOTE

Excepting the wirings for power supply circuit, avoid the laying of input signal wires in parallel or in the same conduit with high-tension or power lines. It is recommended to use shielded wires or wiring with independent metal conduits for the shortest possible distance.