

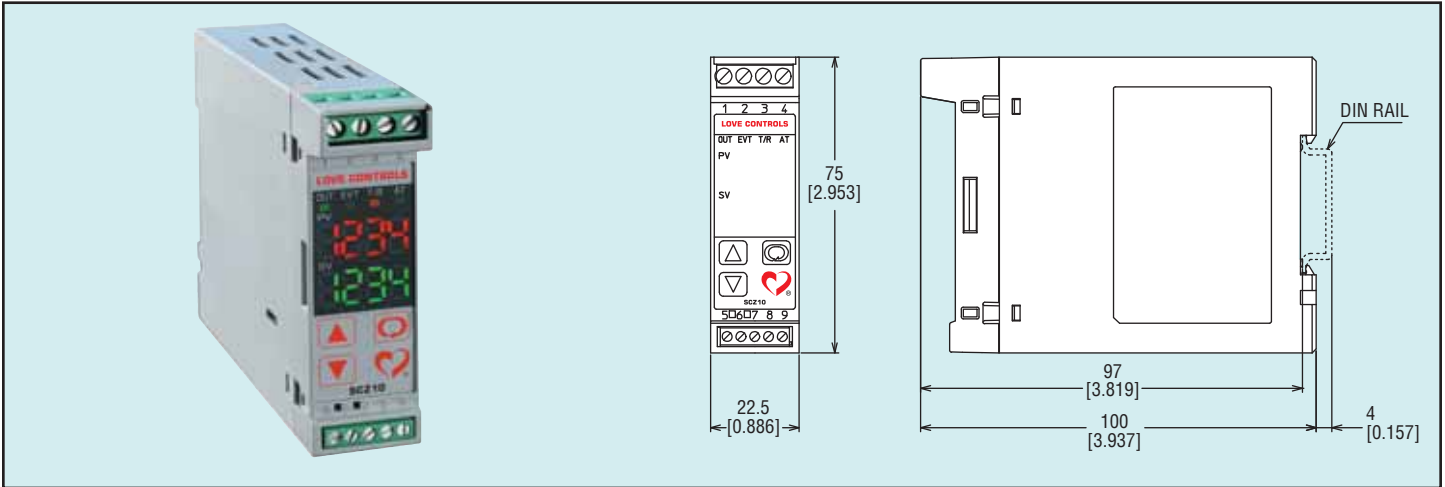

Series
SCZ10

DIN Rail Mount Temperature/Process Control

Universal Input, Two-Color Dual Display



The Series SCZ10 has its own dual display and keypad, making process monitoring and programming a snap. The universal input allows field programming for a wide variety of sensors, making the SCZ10 one of the most flexible controls or transmitters available today. When used as a control, the SCZ10 is available with mechanical relay, switched (pulsed) DC for SSRs, or proportional current (4-20 mA) to drive motor actuators or proportional power units (SCRs). When used as a transmitter, the 4-20 mA output may be scaled virtually anywhere on the input scale, allowing for the greatest application flexibility.

FEATURES

- Dual display
- Control or Transmitter
- Self-Tune and PID
- Directly Programmable from Self Contained Keypad
- Universal Input
- Compact DIN Rail Mount

Model	Supply Voltage	Output
SCZ10-1000-00	120 to 240 VAC	Relay
SCZ10-2000-00		Switched Voltage
SCZ10-3000-00		Current
SCZ10-3100-00	24 VAC/DC	Current

Input Type	Range °F	Range °C
Type J Thermocouple	-320 to 1800	-200 to 1000 ¹
Type K Thermocouple	-320 to 2500 ¹	-200 to 1370 ¹
Type T Thermocouple	-200 to 750 ¹	-200 to 400 ¹
Type E Thermocouple	-320 to 1500	-200 to 800
Type R Thermocouple	0 to 3200	-17 to 1760
Type S Thermocouple	0 to 3200	-17 to 1760
Type B Thermocouple	0 to 3300	0 to 1820
Type C Thermocouple	0 to 4200	0 to 2315
Type PL-II Thermocouple	0 to 2500	0 to 1390
Type N Thermocouple	-320 to 1500	-200 to 800
100Ω Pt. 0.00385 DIN RTD	-300 to 1500 ¹	-200 to 850 ¹
100Ω Pt. 0.003916 JIS1 RTD	-300 to 900 ¹	-200 to 500 ¹
Current/Voltage/Δ Voltage ² Scalable Units from -1999 to +9999		

¹ These input ranges can be set for 0.1° display. Range may be limited to no greater than 999.9° or less than -199.9°.

² The 0 to 20 mADC, 4 to 20 mADC, 0 to 5 VDC, 1 to 5 VDC, and 0 to 10 VDC inputs are fully scalable from a minimum of 100 counts span placed anywhere within the range of -1999 to +9999. Decimal point position is adjustable from the zero place (9999), tenths (999.9) place, or hundredths (99.99) place.

SPECIFICATIONS

Input:

- Thermocouple: K, J, R, S, E, T, N, PL-II, C (W/Re5-26).
- External Resistance: 100Ω or less.
- B Thermocouple: External resistance: 40Ω or less.
- RTD: Pt100, JPt100 3-wire system. Allowable input wire resistance (10Ω or less per wire).
- DC Current: 0 to 20 mAdc, 4 to 20 mA input impedance 50Ω (50Ω shunt resistor sold separately).
- DC Voltage: 0 to 1 VDC.
- Input Impedance: 1MΩ or greater.

Output Ratings:

- Relay Contact: 3A @ 250 VAC, Resistive; 1A @ 250 VAC Inductive (CØS =0.4), Electric life 100,000 cycles.
- Switched Voltage (for SSR drive): 12 VDC @ 40 mA Max. (Short-circuit protected)
- DC Current: 4 to 20 mAdc, Load resistance: Max. 550Ω Output accuracy: ±0.3% of output span. Resolution : 12,000 counts.

Control Type:

P, PI, PD, PID, Self Tune, On-Off, Process Retransmission.

Proportional Band: 0.0 to 110.0% (ON/OFF when set to 0.0).

Integral Time: 0 to 1000 seconds (Off when set to 0).

Derivative Time: 0 to 300 seconds (Off when set to 0).

Proportional Cycle: 1 to 120 seconds.

Manual Reset: Proportional band converted value.

Output Limit: 0 to 100% (DC current output type: -5 to 105%).

Hysteresis: Thermocouple and RTD Input: 0.1 to 100.0 degrees

DC Voltage and Current Input: 1 to 1000 (Decimal point place follows the selection).

Power Requirements: 120-240 VAC, 50-60 Hz, 24 VAC 50-60 Hz optional.

Power Consumption: Approximately 6VA.

Accuracy: Thermocouple Input: ±0.2% of input span, ±1 digit or 4°F (2°C), whichever is greater. R, S input: 0 to 400°F (0 to 200°C): ±6°C (12°F). B input: 0 to 600°F (0 to 300°C): Accuracy is not guaranteed.

K, J, E, N input less than 32°F (0°C): ±0.4% of input span ±1 digit.

RTD Input: ±0.1% of input span ±1 digit or ±2°F (1°C), whichever is greater. DC Voltage Input: ±0.2% of input span ±1 digit. DC Current Input: ±0.2% of input span ±1 digit.

Input Sampling Period: 0.25 seconds, 4 Hz.

PV Display: Red LED 4-digit character size: 7.5 x 4.1 mm (H x W).

SV Display: Green LED 4-digit character size 7.5 x 4.1 mm (H x W).

Display Resolution: 1 count, 1 degree, or 0.1 degree, depending on selected range.

Memory Backup: Nonvolatile memory, no battery used.

Ambient Temperature: 32 to 131°F (0 to 50°C).

Ambient Humidity: 35 to 85%RH (Non-condensing).

Weight: Approx. 5.3 oz (150 g).

Agency Approvals: CE, UL, cUL.