

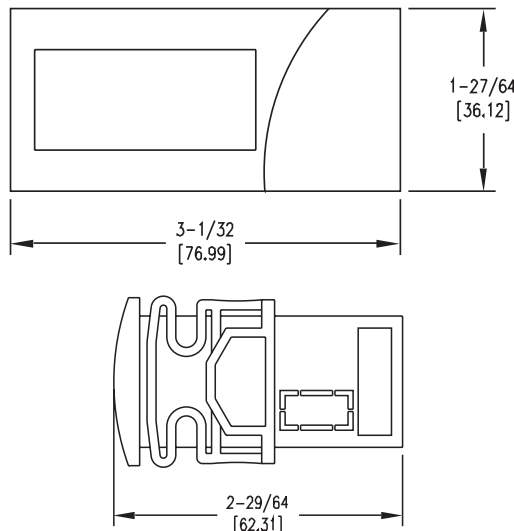

Series TID Temperature/Process Indicator

Specifications - Installation and Operating Instructions



The affordable Series TID allows user to monitor temperature or a process value. Temperature ranges are available from -58 to 302°F using one of our PTC or NTC thermistors. Process values can be displayed from -999 to 999 counts using a 4 to 20 mA signal from one of our various transmitters. The process indicator has an adjustable span and zero on the 4 to 20 mA models.

SPECIFICATIONS

- Inputs:** PTC/NTC thermistor or 4 to 20 mA.
- Display:** 3-digits; red, green or blue display.
- Range:** -58 to 302°F (thermistor); -999 to 999 counts (4 to 20 mA).
- Power Requirements:** 110 VAC, 230 VAC, 12 VAC/DC, 24 VAC/DC.
- Accuracy:** Better than 1%.
- Resolution:** 1° or 0.01 count.
- Front Panel Rating:** IP64.
- Agency Approvals:** CE.

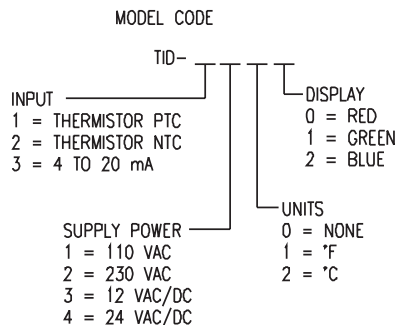

Installation

Note: Unit must be mounted away from vibration, impacts, water, and corrosive gases.

- Cut hole in panel 2.80 x 1.14 in (71 x 29 mm).
- Apply silicone (or rubber gasket) around the perimeter of the hole to prevent leakage.
- Insert unit into hole of panel.
- Slide removable fitting clips onto unit from the back until secure to panel.
- Remove back cover to wire unit.
- Wiring diagram is displayed on the top of the unit.

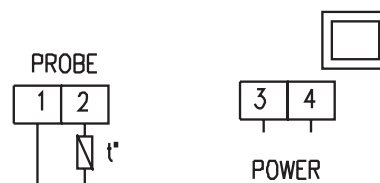

THERMISTOR CONNECTION DIAGRAM

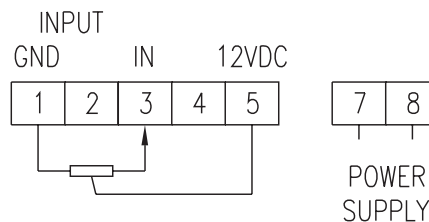

CURRENT CONNECTION DIAGRAM

List of Parameters (Current Models Only)

	Description	Units	Range
Lc	Value for 4 mA input	Range	-999 to 999
Hc	Value for 20 mA input	Range	-999 to 999
P1	Decimal Point	Selection	no yes
H5	Access code	Numeric	0 to 99

Parameter Descriptions

Lc = Value for 4 mA input

If P1 = Yes the value is displayed with decimal point

Hc = Value for 20 mA input

If P1 = Yes the value is displayed with decimal point

P1 = Decimal Point

If P1 = Yes LC, Hc and probe values are displayed with decimal point

H5 = Access code to parameters

Parameter Programming

- Press SET for 8 seconds. The Access code value 00 is shown on the display (unit comes with code set at 00 from factory).
- With the UP and DOWN arrows, code can be set to user needs.
- Press SET to enter the code. If the code is correct, the first parameter label is shown on the display (Lc).
- Move to the desired parameter with the UP and DOWN arrow keys.
- Press SET to view the value on the display.
- The value can be modified with the UP and DOWN arrows.
- Press ENTER to enter the value and exit.
- Repeat until all necessary parameters are modified.
- Press SET and DOWN at the same time to quit programming or wait one minute and the display will automatically exit programming mode.

* The keyboard code can be reset to ZERO by turning off the controller and turning it on again while keeping the SET key depressed.

Display Message

The display normally shows the temperature of the probe. In case of error the following messages are shown:

- Er = Memory error
- 00 = Open probe
- -- = Short circuit probe

Maintenance, Cleaning and Repair

After final installation of the unit, no routine maintenance is required.

Clean the surface of the display controller with a soft and damp cloth. Never use abrasive detergents, petrol, alcohol, or solvents.

All repairs must be made by authorized personnel.