

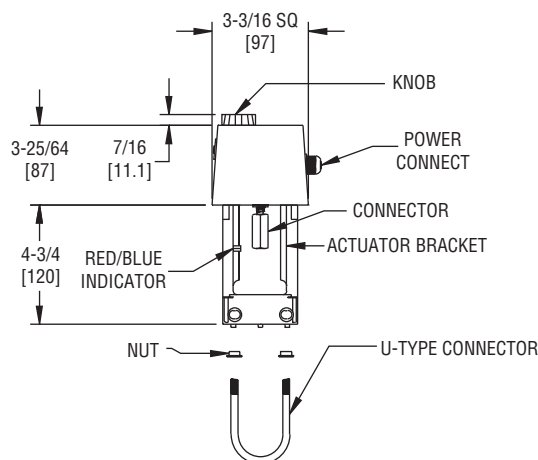

## Series EVA1 Electric Actuator

## Specifications - Installation and Operating Instructions



The Series EVA1 Electric Actuators are designed to mount directly onto the Series GV globe valves, creating a complete, low cost, and compact control valve package. Floating or modulating control inputs are available, and the 24 VAC synchronic motor includes a magnetic clutch to protect the motor in stall conditions. Actuators are ruggedly constructed with a fire-proof ABS housing and robust aluminum bracket. Features include a visual position indicator and manual override to make this actuator an excellent choice for any size area, large or small.

**FEATURES**

- Manual Override
- Compact Size
- Floating Control or Selectable 0-10 VDC or 4-20 mA Proportional Control
- Reversible Direction on Proportional Models
- Magnetic Clutch Protects Motor in Stall Conditions

Model	Actuator Action	Output Force	Valve Size	Compatible Valve Model
EVA1F	Floating	112 lb (500 N)	1" to 2"	GV1__
EVA1M	Modulating	112 lb (500 N)	1" to 2"	GV1__

**SPECIFICATIONS**

**Output Force:** 112 lb (500 N).  
**Power Requirements:** 24 VAC.  
**Power Consumption:** EVA1F: 2.5 VA; EVA1M: 4.5 VA.  
**Cycle Time:** 262 sec/in. (10.3 sec/mm).  
**Enclosure Rating:** IP54.  
**Housing Material:** Fire-proof ABS plastic (UL94V-0).  
**Bracket Material:** Aluminum.  
**Operating Temperature:** 36 to 131°F (2 to 55°C).  
**Storage Temperature:** -4 to 149°F (-20 to 65°C).  
**Humidity Limit:** <90%, non-condensing.  
**Electrical Connection:** Screw terminal.  
**Modulating Input:** 0 to 10 VDC or 4 to 20 mA.  
**Weight:** EVA1F: 1.81 lb (0.8 kg); EVA1M: 1.92 lb (0.9 kg).

**INSTALLATION**

1. Tightly screw the valve connector on the valve body. Please pay attention to the direction of the connector.
2. Install the actuator bracket on the valve connector.
3. Insert the U-type connector into the bracket, and lock the connector nut.
4. Lift up the valve stem and put the lock nut and indicator guide onto it, then rotate the connecting rod of the actuator and let it rotate onto the valve stem. Use spanner to lock the locknut after adjusted into position.
5. In vertical installations, leave enough head room to unscrew the actuator prior to servicing the valve body.
6. Wire the unit according to the appropriate Wiring Diagram.

### EVA1F WIRING DIAGRAM

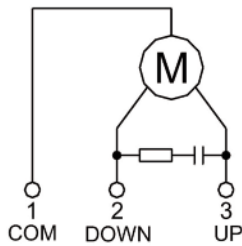

TERMINALS	ACTUATOR ROD
1-2	DOWN EXTEND
1-3	UP CONTRACT

### EVA1M WIRING DIAGRAM

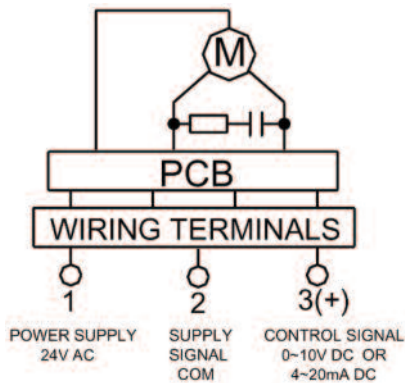

INPUT CONTROL SIGNAL		ACTUATOR
DA	RA	ROD
INCREASE	DECREASE	DOWN
DECREASE	INCREASE	UP

**Note:** Actuator must be protected from dripping water. Damage to internal elements and motor may occur. Do not cover actuator with material that does not permit heat exchange.

### OPERATION

1. The actuator is driven by a reversible synchronous motor with a magnetic clutch. The motor can provide stable torsion at stopping conditions due to the magnetic force created by the motor rotor and the magnetic clutch. When power is taken away, the motor will stop at its current position.
2. The signal of the proportional type actuator controls the clockwise or counter-clockwise rotation of the motor.
3. EVA1M actuators can be jumper selected for 0.51, 0.59, 0.67 or 0.75 inch valve strokes. Factory stroke setting is 0.75".
4. The input control signal is jumper selectable between 0-10V or 4-20 mA DC. Factory setting is 0-10V DC input mode.
5. Direct (DA) or Reverse (RA) direction operation is also jumper selectable. The two states are opposite of each other.

### EVA1M PCB SETTING DIAGRAM

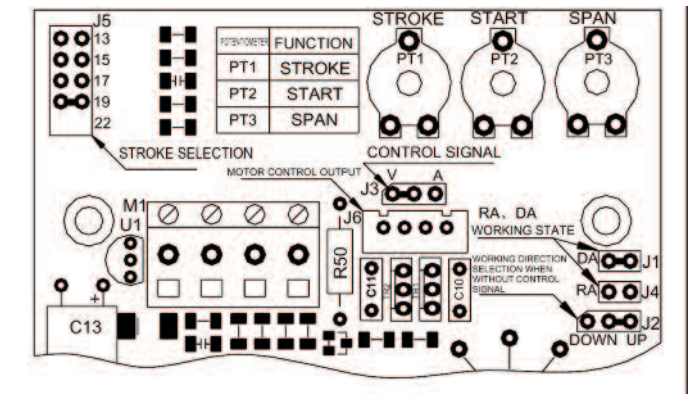

### MAINTENANCE

The Series EVA1 Electric Actuator is not field serviceable and should be returned if repair is needed (field repair should not be attempted and may void warranty). Make sure to cut off power supply when disconnecting the actuator from the valve. Contact customer service to receive a return goods authorization number before shipping. Be sure to include a brief description of the problem plus any relevant application notes.