



Model
MC6

Multi-Cal Benchtop Calibrator



Interchangeable Ranges, $\pm 0.05\%$ Accuracy, Datalogging Capability, NIST Traceable

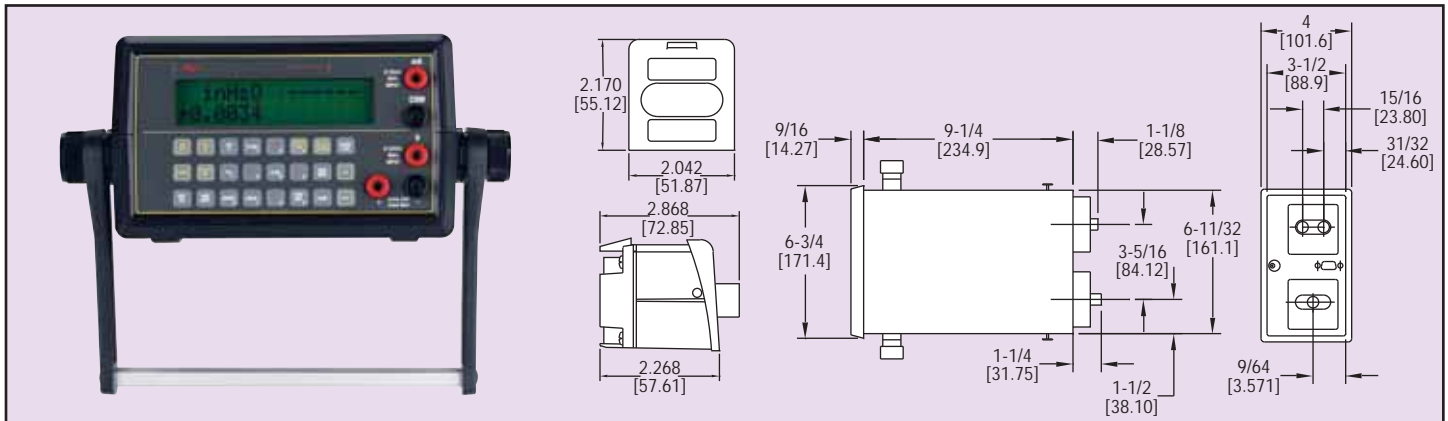

Model MC6 Multi-Cal Benchtop Calibrator performs a wide variety of simple and complex pressure based measurement, test, and calibration operations. Modular sensor design allows user to select pressure measurement range for application flexibility. Calibrator can accommodate up to two interchangeable pressure modules (sold separately below) in any combination of range or accuracy. Simultaneously display two separate measurements on the two line, alphanumeric display. Readings can be displayed in a choice of twelve preprogrammed engineering units or any single user-defined unit. Calibrator features min/max recall, hi/lo alarm, percentage of full scale pressure readings, mA/voltage measurement, leak rate and pressure decay measurement, switch testing capabilities, including trip point and dead band, and velocity/volume flow rates. Quickly document calibration procedures using the data logging feature which stores up to 384 sets of pressure and time/date stamped measurements. The automatic % error calculation simplifies transmitter calibration. Easily upload stored data to an IBM compatible computer via the RS232 two-way communications port. Calibrators and modules include certification to NIST traceability—ideal as a secondary standard for calibrating pressure equipment. Multi-Cal Pressure Calibrator includes utility software, protection module, adjustable handle, AC adapter, and instruction manual.

Model MC6, Benchtop Calibrator

Multi-Cal Pressure Modules are interchangeable and available in a wide selection of pressure ranges and accuracies. Benchtop calibrator accepts up to two pressure modules. Modules include NIST calibration certification.

Model	Range
MC1000	0.25" H ₂ O Differential Pressure, ± 0.07
MC1001	0.50" H ₂ O Differential Pressure, ± 0.07
MC1004	5.00" H ₂ O Differential Pressure, ± 0.06
MC1006	25" H ₂ O Differential Pressure, ± 0.06
MC2010	5.0 psig Gauge Pressure, ± 0.05
MC2012	15.0 psig Gauge Pressure, ± 0.05
MC2016	100.0 psig Gauge Pressure, ± 0.05

OPTIONS

Consult factory for other pressure ranges and accuracies.

SPECIFICATIONS

Service: Clean, dry, nonconductive, noncorrosive gases.

Accuracy: Differential pressure modules: $\pm 0.06\%$ FS; Gauge pressure modules: $\pm 0.05\%$ FS; Voltage input: $\pm 0.025\%$ FS @ 0/10 VDC, $\pm 0.10\%$ FS @ 0/30 VDC; Current input: $\pm 0.03\%$ FS @ 0/20 mA, $\pm 0.05\%$ FS @ 0/50 mA.

Sensitivity: $\pm 0.002\%$ of span with dampening 1 part in 50,000 (max).

Repeatability: Ranges $\leq 0/2$ psi: $\pm 0.05\%$ of span; Ranges $\geq 0/5$ psi: $\pm 0.02\%$ of span.

Output: RS232 serial interface, 9-pin.

Alarm Output: SPST form C 110 VDC, 120 VDC (max.), 1 A (max), 30 W, 62.5 VA (resistive).

Display: Alphanumeric LCD, 0.37" (9.5 mm) height per line, 2 lines, 16 characters/line.

Display Update: 100 msec.

Ambient Operating Temperature: 32 to 120°F (0 to 49°C).

Storage Temperature: -4 to 158°F (-20 to 70°C).

Process Connection: 1/8" female NPT.

Electrical Connections: Standard banana jacks.

Power Supply: 110 VAC/60 Hz adapter, 500 mA.

Engineering Units: in H₂O, psi, in Hg, kPa, mbar, bar, cm H₂O, mm Hg, ftSW, MPa, mmH₂O, kg/cm² and user-defined.

Overpressure: Differential pressure modules: 50 psi positive direction, 15 psi negative direction; Gauge pressure modules: 2x range (0/5 psi to 0/1000 psi).

Temperature Compensation: 20 to 120°F (-7 to 49°C).

Temperature Error: Maximum of $\pm 0.004\%$ of span per °F over compensated range for zero and span.

Temperature Effect Electrical Measurement: $\pm 0.001\%$ of span per °F over compensated range.

Dampening: (Measurement averaging) programmable from 0 to 16 consecutive readings.

Baud Rate: 300, 1200, 2400, or 9600, selectable.

Computer Requirements: IBM compatible 386 or above and Windows® 3.1 or later with 2mB RAM and 2mB hard drive disk space, one serial port.

Housing Material: ABS plastic.

Weight: Calibrator: 3.0 lb (1.4 kg); Pressure module: 0.5 lb (0.3 kg).

Agency Approvals: CE.

APPLICATIONS

Pressure measurement for clean room control, filter performance monitoring, HVAC testing and setup, draft measurement, airflow measurement control, differential pressure measurement in laminar flowhoods, paint booths, industrial ovens and fume hoods. Use as a secondary standard for calibrating pressure equipment.

Windows® is a registered trademark of Microsoft Corporation